

Looking for Archibald

A Detective Story

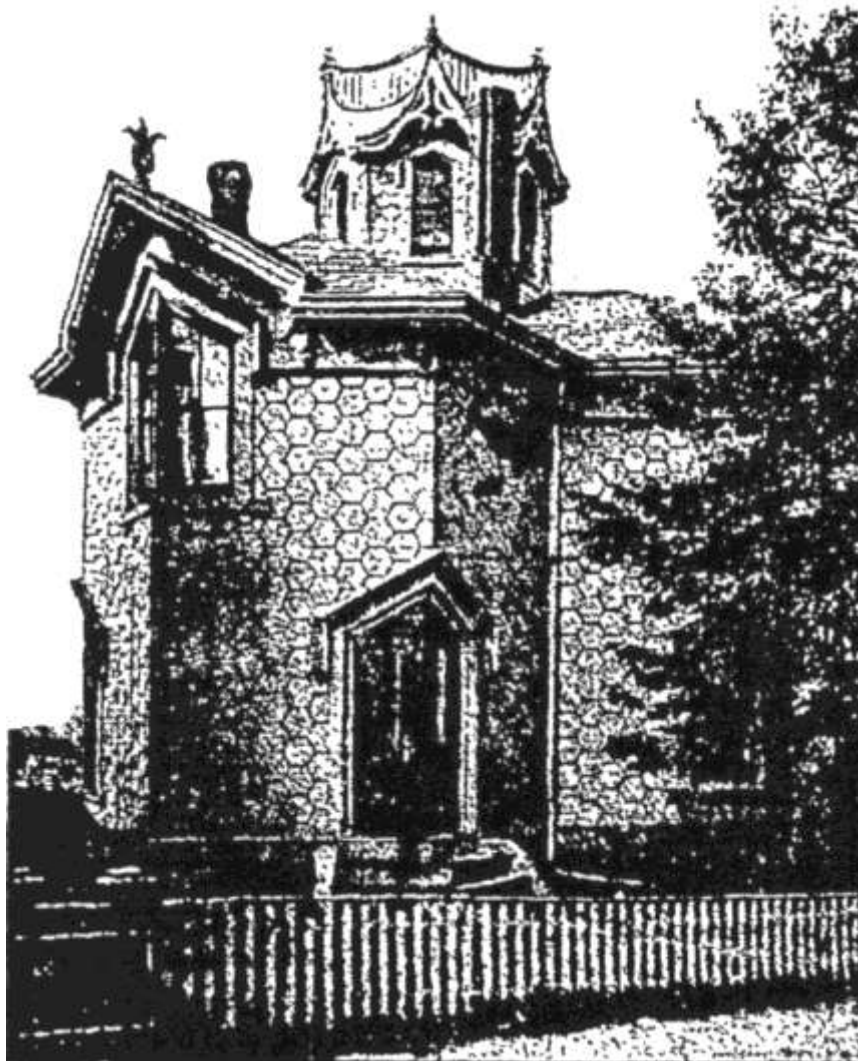

We bought our house on Cranston Street
in 1996.



It has a strange geometry...basically 3 hexagonal columns
“pressed together”.



As seen from above the house is 12-sided, with 6-sided rooms and a hexagonal cupola sitting on top like a crown.

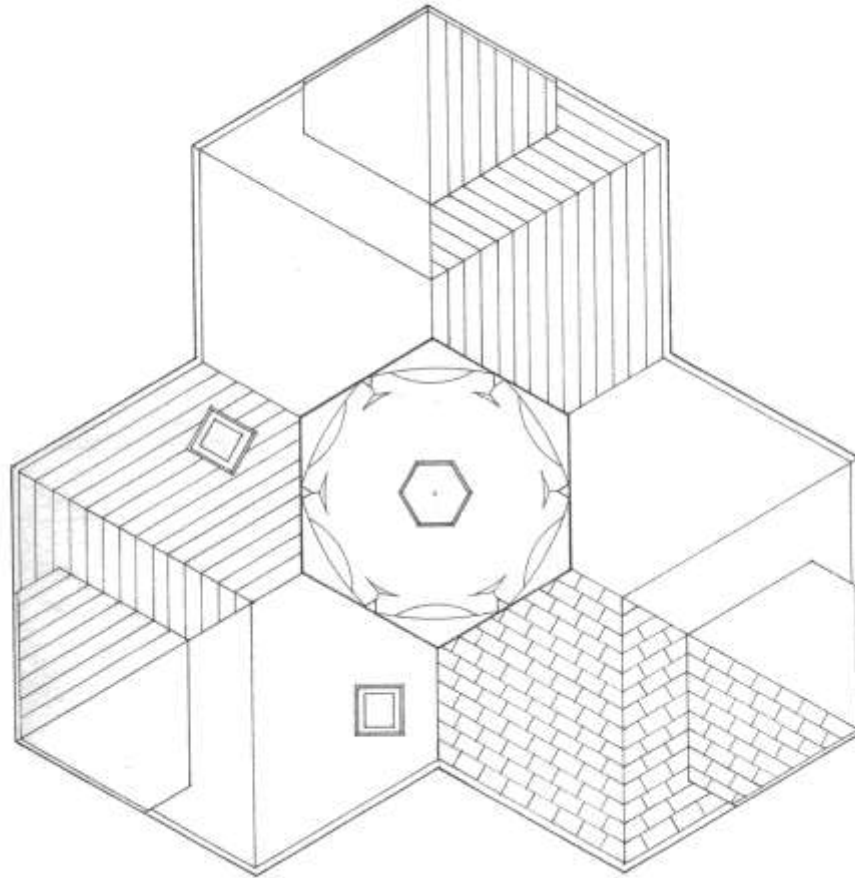

Thanks to John Raisz for
this drawing

A few years after moving in we decided to remove the asphalt roofing shingles that covered the house.



This exposed the interlocking wooden hexagonal shingles underneath (originally they were painted to resemble stone).



Also, in every window there's a hexagon...



...and every window is different.



There's even a six-sided hatch that leads up to the roof.



Back in 1987 our house had been included in the National Register of Historic Places. When we moved in we received a copy of the Boston Landmarks Commission report recommending it. Among other things it said:



“The deed and mortgage records indicate that John and Archibald Scott, in 1871, acquired a lot of land at 17 Cranston street (then 16 Terrace Avenue)...”

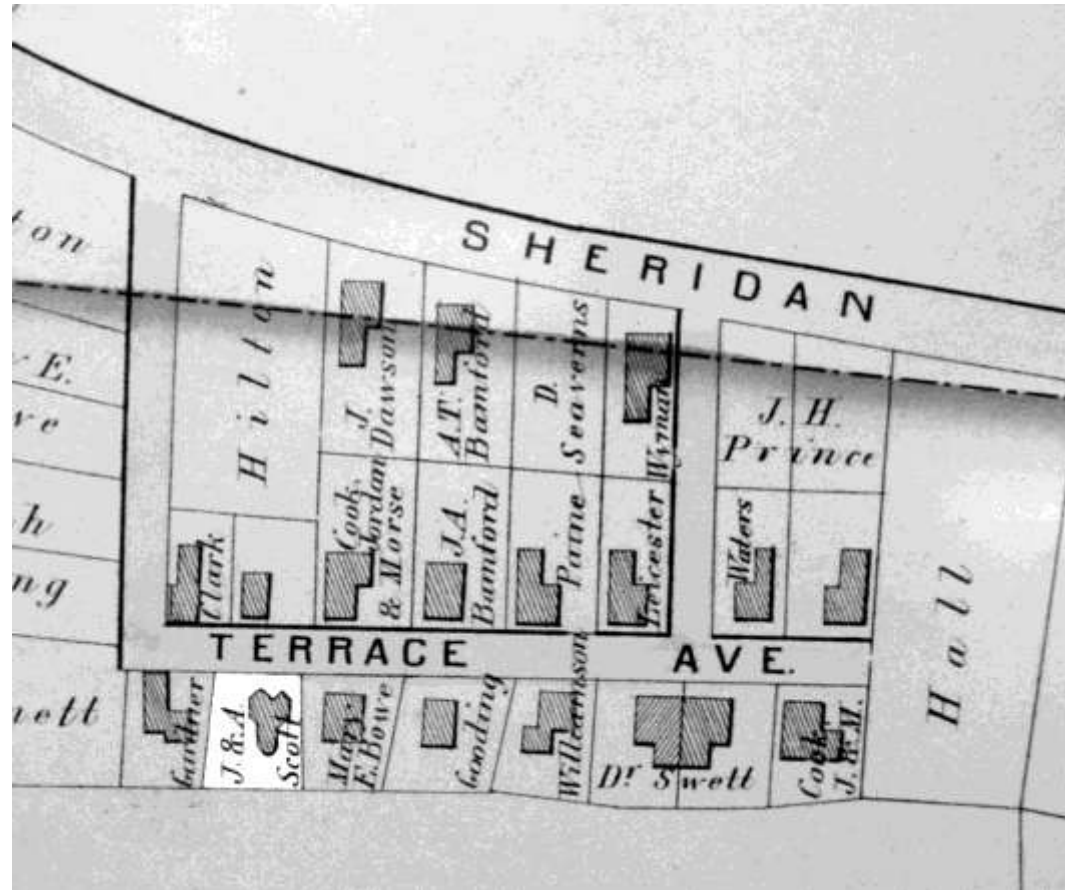

(Hopkins, 1874)

“...Archibald Scott (b. 1831, Nova Scotia, Canada) was listed as early as 1860 as an organ factory worker...”



“He may have been responsible for the design of the house, which does display an eccentric attitude toward architectural form...”



...and a vigorous handling of shape and detail...



...that may indicate a building tradition...



...outside that of housing construction.”

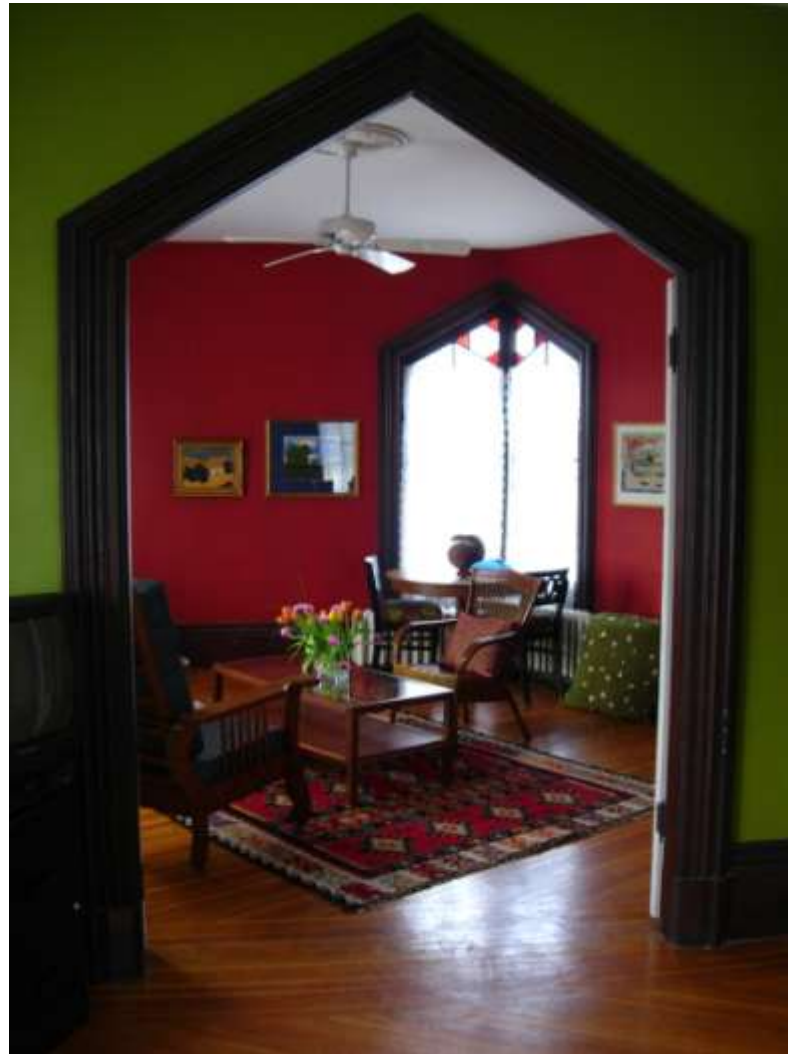

It was a most unusual house . I wanted to know why?
How hard could it be???

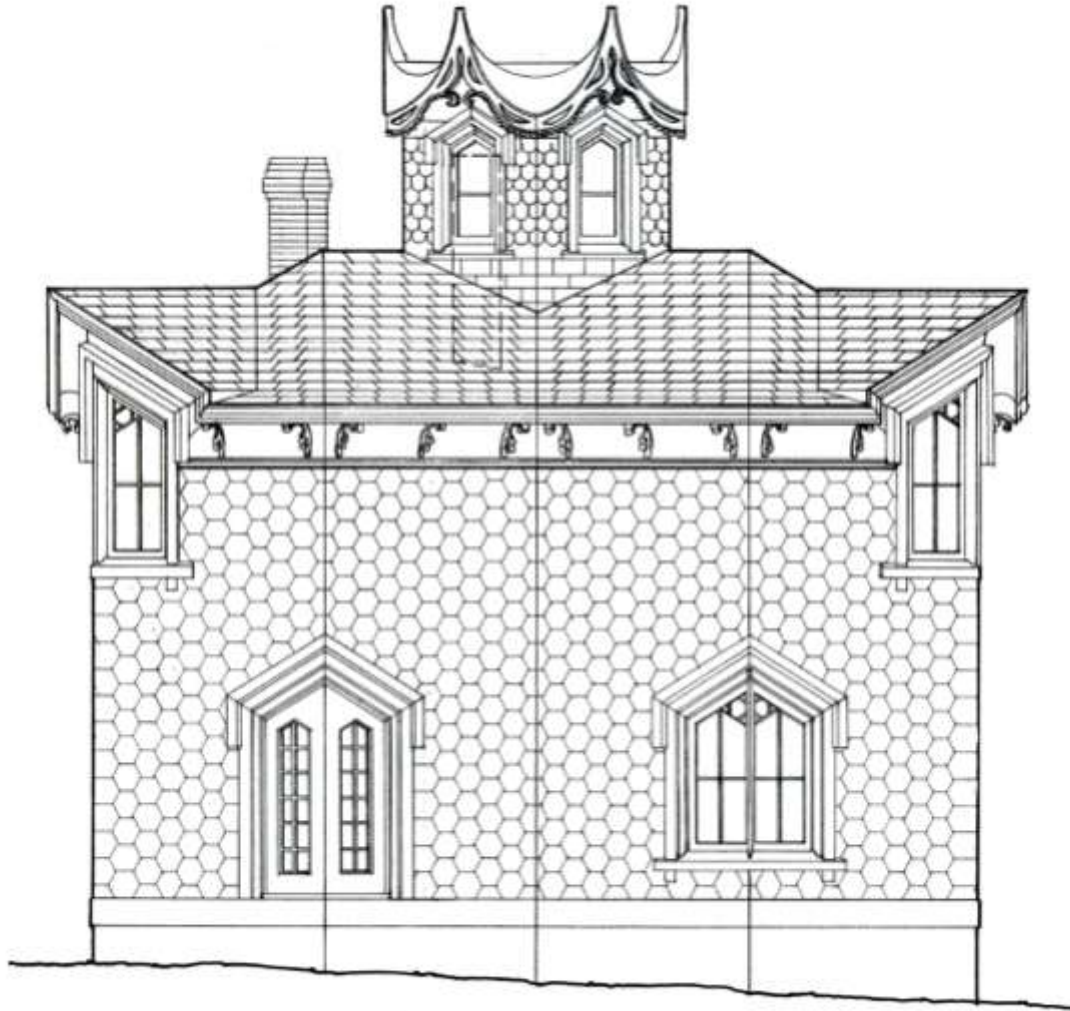

Thanks to John Raisz
for this drawing

So I decided on two different strategies.

First, I'd research **Archibald Scott**.

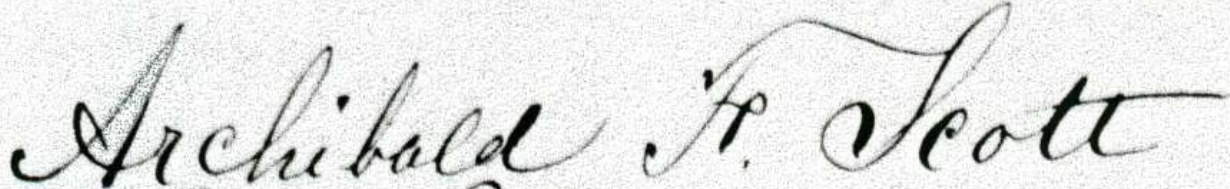

Archibald F. Scott
District Organ Builder an Alien, and a free white
Halifax Nova Scotia

Second, I'd contact **previous tenants** and see if they had any interesting stories... about Archibald or the house.



I started my research at the **Boston City Archives** in West Roxbury.



In 1871 & 1872 we find **Archibald & John Scott** paying taxes first for land and then an “unfinished house” on Cedar Hill (another name for Cranston Street /Terrace Avenue).

Town of West Roxbury. State, County, and Town Tax for 1871.

NAMES.	No. P.	Poll Tax.		Real and Personal Estate.		TOTAL
		DOLLS.	CTS.	DOLLS.	CTS.	
Scott George At J. J. Leakes & Walnut St	1	2	00			2
Sullivan Roger At Michael Banks & Cambridge St	1	2	00			2
Storrs E. W. At George & Union Square	1	2	00		12 75	14
Sargent Joseph At J. J. Greenough & Third of State	1	2	00	1 70		3
Scott Archibald & John Land Cedar Hill	1	2	00	4 25		6
Sumner Mrs S Unfinished House and Spring Hill				3 00		3
Sumner Mary D. M. House Southland James Hill				222 70	57 00	279

Town of West Roxbury. State, County, and Town Tax for 1872.

NAMES.	LOCATION.	No. P.	Poll Tax.		Real and Personal Estate.	
			DOLLS.	CTS.	DOLLS.	CTS.
Scott A	Cedar Hill	1	2	00		
Scott J.	" "	1	2	00		
Scott A & J	Union & Land "				16 48	
Steele Roman	Park St & Land "				14 42	
Singer Margarett	H & Land Chestnut "				41 20	
Scholar John	Land Spring Lane				3 09	
St. John E. P. Society	House Centre "				20 60	

... in 1874 Archibald & John run out of money! The land and house were sold at public auction.

MORTGAGEE'S SALE.

To JOHN SCOTT and ARCHIBALD SCOTT, the supposed owners of the equity of redemption of the following described estate, and any others interested therein:



By virtue of a power of sale, and by reason of a breach of the conditions contained in a certain mortgage deed given by said John and Archibald Scott to Timothy F. Howe, dated March 23, 1871, and recorded with Suffolk Deeds, lib. 405, fol. 29 will be sold at public auction, on the premises, on MONDAY, June the eighth, 1874, at 3 o'clock P.M., a lot of land, with the buildings thereon, being a lot numbered sixteen upon Terrace avenue, on Garbett's plan, dated December 16, 1870, and recorded with Norfolk Deeds as plan No. 191, said estate being formerly in West Roxbury, but now in Boston; bounded northeasterly by a line through the centre of said Terrace avenue fifty feet and 25-100, southeasterly by lot numbered 17 eighty-five 7-10 feet, southwesterly by land of Gore fifty and 5-10 feet, and northwesterly by lot No. 15 eighty-five 2-10 feet, with a right of way through said Terrace avenue and subject to the restrictions that a strip of land seven and a half feet wide across the entire northeasterly end of said lot is forever to be kept open as a part of said avenue.

WILLIAM LOCK,

Assignee of said Mortgage.

At the **State House Library**, Special Collections, I went through the **Boston Directories**.

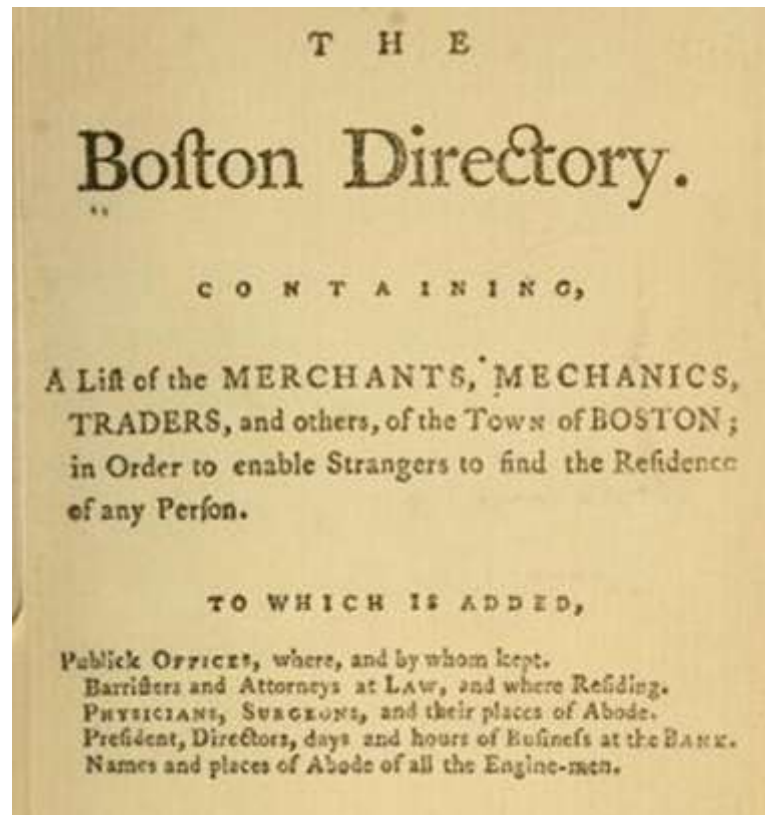

I found **A.F. (Archibald Fraser) Scott, organ builder**, listed from 1860-1888, living at a variety of Boston addresses.

BOSTON [S] DIRECTORY.	
Scott Augustus E. counsellor, 7 Court sq. rooms 5 and 7, house at Lexington	Scott Nathan W. steamfit
Scott A. F. organ builder, house 9 Avon pl. wd. 15	Scott O'Neil E. watchm
Scott Bartholomew, teamster, boards 48 Elliot	Quincy House
Scott Catharine, widow, house 1 Oswego	Scott Owen, laborer, hou
Scott C. W., N. E. Agent Nat. Fire Ex. Co. 49 Water	Scott Patrick H. dry good
Scott C. W. jr. physician, house 1 Asylum	Shawmut avenue
Scott Daniel, laborer, house 342 North	Scott Patrick J. house 106
Scott Daniel, laborer, house 1 Page's court	Scott Peter B. porter, 51
Scott Daniel, jr. chair driver, 60 North, boards 7 Cambridge	Scott Richard, laborer, h
Scott Daniel A. blacksmith, house Dor. avenue, near house Eagle, near Putnam	Scott Robert, cotton brok
Scott Edward, pianomaker, house 71 Circuit	Scott Robert, agent, 8 Pe
Scott Edward, house 5 No. Anderson	Scott Russell, carpenter.
Scott Edwin M. (<i>Lewis & Scott</i>), 284 Broad, house at Charlestown [house 4 Washington place	Scott S. W. 242 Washing
Scott Elbridge G. life-insurance agent, 22 Guild row	Scott Thomas, laborer, h
Scott Elizabeth, widow, house 49 Hudson	Scott Thomas, laborer, h
Scott Frank, carpenter, house Charles, near Dor. avenue, ward 16	Scott Thomas, mason, h
Scott Frank A. salesman, house 10 E. Lenox	Scott Thomas, pianomak
Scott Frank J. 16 Oliver, house 10 E. Lenox	Scott Thomas, agent, Ast
Scott George (<i>Almond & Scott</i>), 364 Washington, house at E. Somerville	field, house at Somer
Scott George, boards r. 180 North	Scott Thomas, lithograph
Scott George, builder, house 8 Glenwood	Scott Thomas A. salesma
Scott George & Co. granulated soap, 146 Commercial, house at Chelsea [place	Scott Thomas A. clerk, h
Scott George A. clerk, 431 Hanover, bds. 4 Vernon	Scott Thomas E. lab orer,
Scott George A. driver, fire engine 8, house 29 Wall	Scott Thomas E. clerk, 16
Scott George B. carpenter, house 503 Eighth	Scott Thomas H. captain
Scott George C. (<i>H. C. Whitcomb & Co.</i>), 15 Water, house 64 K	Scott Walter, machinist,
Scott George E. sailmaker, house 45 Charter	Scott Walter, baker, hou
Scott George F. grocer, 922 Albany, b. 69 Palmer	Scott Walter, hairdresser
Scott Geo. H. blacksmith, boards 219 Cambridge	Scott Walter W. clerk, 16
Scott George M. (<i>Scott & Bridge</i>), 14 City wharf, house at Charlestown	Scott Warren L. coachm
Scott George T. clerk, U. M. L. I. Co. 27 Court, bds. 4 Washington place	Scott William Mrs. hous
	Scott William, shipwrig
	Scott William, furniture,
	Scott William, carpenter
	Scott William, plumber,
	Scott William, laborer, h
	Scott William J. travell
	at Burlington, Vt.
	Scott William M. glas. &
	Scott William P. cooper
	Scott William W. 67 Dev
	Scott Willis, clerk, 133 F

Next I went in search of the original deed and mortgage at the **Norfolk Registry** in Dedham (Terrace Avenue was part of West Roxbury until 1874!)



Archibald & John paid Timothy Bowe \$1492 for "lot number 16 upon Terrace Avenue".

Know all men by these presents
One \$7.30 Int. Rev. stamp } that I Timothy J. Bowe of Boston in the coun- Bowe
marked "T. J. B. Mch. 23. 1871" ty of Suffolk and commonwealth of Massa- in
chusetts in consideration of fourteen hundred ninety two & 100/100 dol Scott Val
lars to me paid by Archibald Scott and John Scott of West Roxbury in

the county of Norfolk and said commonwealth the receipt whereof
is hereby acknowledged do hereby give grant bargain sell and
convey unto the said Archibald Scott and John Scott a lot of land
in said West Roxbury being lot number sixteen upon Terrace Ave-
nue on Garbett's plan dated Dec. 16. 1870 and recorded with Norfolk
deeds as plan no. 191: said lot is bounded northeasterly by a line

After this followed many “dead ends”:

- **Inspectional Services Department:** No Permit
- **Boston Public Library:** No photos, books or articles about Archibald or the house



Ma Historical Society & Historic New England: nada!



At this point I decided to concentrate on the genealogical route even though I knew nothing about genealogical research. I joined the **New England Historic Genealogical Society (NEHGS)** on Newbury Street...



...and learned how to use their resources:

- **Ancestry.com**
- **FamilySearch**

About Ancestry.com

With 7 billion genealogical records from across the globe and millions of family trees, we are the world's largest online family history resource.
Historical records + family trees + helpful tools + support



"I had no idea I could actually see my father's name written in a census record. But there he was in an orphanage in 1920."
~ MARTIN ASDORIAN JR.



FAMILYSEARCH
A service provided by THE CHURCH OF JESUS CHRIST OF LATTER-DAY SAINTS

Home Search Records Index Records Share Research Helps Library Help

Search Records for Your Ancestors

Online birth, marriage, death, census, church and other indexes.

First and Middle Name(s) Last or Family Name

Life Event Year Year Range

Country or Region

Search Advanced Search

Start Your Family History

Get started with research guidance by location, forms, maps, guides and free online resources. Search records and indexes for more information.

Get started...@

What's New
Celebration of Family History event videos
Help create free public access to U.S. census indexes
See prototype for searching millions of records
Family History Lesson Series provides useful guides

Family History Library
Free Online Classes
Research Series and Special Events
Monthly Class Schedules
African American Family History Resources
Jewish Family History Resources
Hispanic Family History Resources
Recursos de Historia Familiar (Español)

Free PAF Family History Software
Personal Ancestral File (PAF) is a free genealogy and family history program. PAF allows you to quickly and easily collect, organize and share your family history and genealogy information.
* Download PAF

- **The U.S & Canadian Censuses**

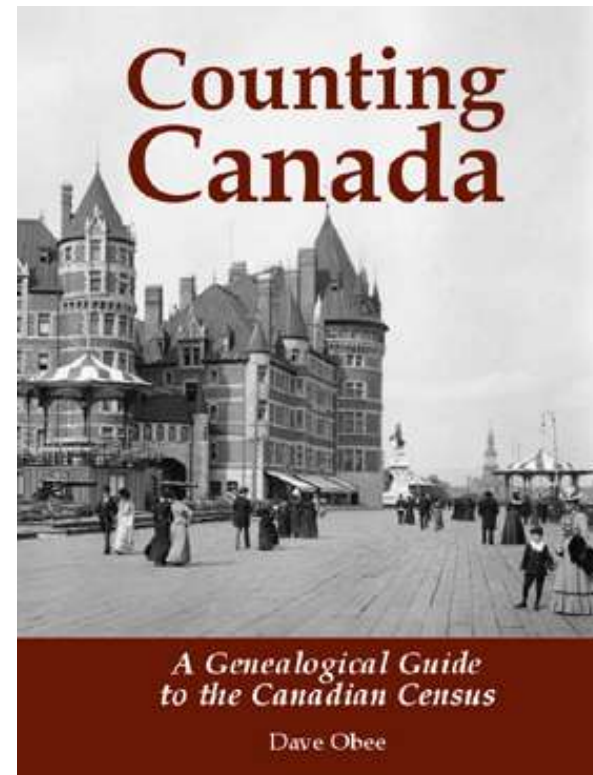
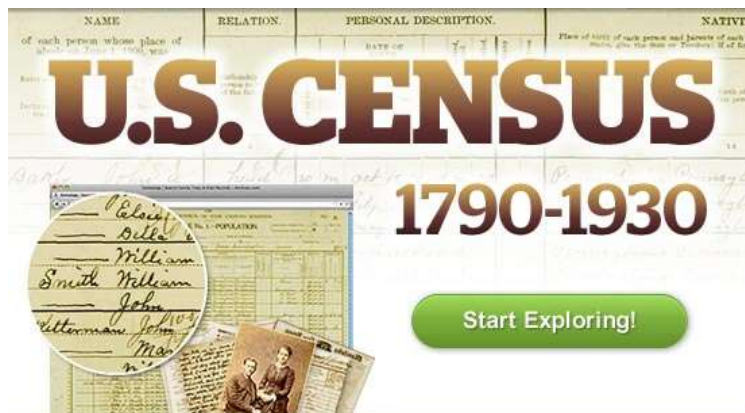

- **Nova Scotia Historical Vital Statistics**

The screenshot shows a web browser window titled "Historical Vital Statistics Start Page - Windows Internet Explorer". The address bar shows the URL "http://www.novascotiagenalogy.com/". The page features a header with the Nova Scotia flag and the text "NOVA SCOTIA CANADA" and "Nova Scotia Historical Vital Statistics". Below the header, there is a navigation menu with links for "Background", "Release Policy", "Birth Registrations", "Marriage Registrations", "Death Registrations", "Order Information and Fee Schedule", "Frequently Asked Questions", and "Contact Us". The main content area includes a welcome message: "Welcome to one million new possibilities in searching for your Nova Scotia roots!" and a "Quick Search" section with input fields for "Last Name" and "Given Name(s)", and buttons for "Births", "Marriages", "Deaths", "Search", and "Reset". Below the search section, there is a paragraph of text: "When you enter this Website, you'll find a fully searchable database containing one million names. Every name is linked to its original record, which will be within one of the following record groups: Births 1864-1877 Marriages 1864-1938 Deaths 1864-1877 and 1900-1955. You'll be able to view the actual record in digitized form, and by using the Viewport8 plug-in that will be provided, you'll also be able to read every detail entered on the original registration. If you want copies of the records for historical and genealogical research purposes, you can purchase them - either e-files at \$9.95 each, or paper copies at \$19.95 each - right here online and securely, as part of our Website service." At the bottom, there is a small image of a historical scene and a paragraph of text: "Nova Scotia Archives and Records Management is pleased to bring you this outstanding new resource for genealogical research. We also acknowledge the assistance and cooperation provided by our record custodians in digitizing and delivering this resource: Vital Statistics of Nova Scotia and..."

Archibald F. Scott was born around 1831 (1870 minus 39) in Nova Scotia. He was married to **Mary** and had 3 girls and he was working in an **organ factory**.

Scott, Archibald	F	39	M	W	works in Organ factory	300	Nova Scotia
- Mary	F	38	F	W	Keeping house		—
- Georgina	F	15	F	W	No occupation		Mass
- Hattie H.	F	10	F	W	Attending school		—
- Irene V.	F	4	F	W	At home		—

Using Ancestry.com & FamilySearch I found the marriage record of Mary (Crowe) Shaffroth and Archibald F. Scott on June 14th 1860. I found the names of both their parents and that both were born in **Halifax**.

11	14	Scott Archibald F.	Roxbury	27	Organ Binder	Halifax N.S.	Archibald & Isabella	first
		Shaffroth Mary F.	Roxbury	27		Halifax N.S.	John & Cloza Crow	second

...married to **Elizabeth** and 3 boys have been added to the family!

Scott. A. F.	W. 11 48	+	Husband	1	Organ Builder
— Elizabeth	W. 5 38	+	Wife	1	Keck House
— Harriet	W. 7 18		daughter	1	Carpet Factory
— Irene	W. 7 14		daughter	1	at School
— Thomas	W. 11 12		Son	1	at School
— Walter	W. 11 4		Son	1	
— Charles	W. 11 1		Son	1	



Death records confirm that Mary died in 1872 at 40 years old of tuberculosis. Marriage records confirm that Archibald married Elizabeth Short from England two years later in 1874.

No.	Sex	Age	Residence	Occupation	Place of Birth	Parents	Spouse	Parents of Spouse	Spouse's Birthplace
Edward Cartwell	M	4	Chelsea	Whol. Infanterie	St. Louis, Mo.	Horatio Elizabeth	Elizabeth	John	England
Edward Cartwell	M	5	Chelsea	Whol. Infanterie	St. Louis, Mo.	Horatio Elizabeth	Elizabeth	John	England
Mary La. Scott	F	40	Chelsea	Non Tubercularis	157 Linden Park	Wife of Archibald	John Elizabeth	John Elizabeth	England
Mary F. White	F	7	Chelsea	Whol. Infanterie	No. 100	John Mary	John Mary	John Mary	England
Joseph Schiffo	M	2	Chelsea	Porter	Spring St.	Joseph Elizabeth	Joseph Elizabeth	Joseph Elizabeth	England
Mary O. Griffin	F	3	Chelsea	Whol. Infanterie	No. 4	John Elizabeth	John Elizabeth	John Elizabeth	England
Thomas F. Turner	M	9	Chelsea	Whol. Infanterie	144	John Elizabeth	John Elizabeth	John Elizabeth	England

[PAGE 109]

MARRIAGES REGISTERED IN THE City of Boston for the Year eighteen hundred and seventy-four

No.	DATE OF MARRIAGE	NAMES, SURNAMES, AND COLOR OF GROOM AND BRIDE.	RESIDENCE OF EACH AT TIME OF MARRIAGE	AGE of each in Years	OCCUPATION OF EACH.	PLACE OF BIRTH OF SAID.	NAMES OF PARENTS.	WHAT MARRIAGE, Whether 1st, 2nd, 3rd, &c.	NAME AND OFFICIAL STATION OF PERSON BY WHOM MARRIED.
1903	June 29	Frank S. Spencer Emma Dull	Boston	21 15	Clerk	Wilton Cambridge	Charles William	1st. 2nd.	Rev. Rufus Ellis Boston
196	June 29	Archibald S. Scott Elizabeth Short	Boston	41 35	Organ-builder	Nova Scotia England	Archibald Thomas	1st. 2nd.	G. S. Converse Boston
197	June 29	Abraham Kell Walter Sparks	Chelsea Boston	24 25	Printer	New York City Waltham N. H.	Walter Alice	1st. 2nd.	Abraham Kell Boston
198	June 29	John P. Flynn	Chelsea	27	Printer	New Bedford	William Mary	1st.	Thomas Kenyon Boston

At the **National Archives** in Waltham I found Archibald's Naturalization papers...



...stating that Archibald (born 2-9-1831) came from Halifax and arrived in Boston in 1847...

United States of America.

To the Honorable the Judges of the **Circuit Court of the United States,**
begun and holden at *Boston*, within and for the *District of Massachusetts.*

Respectfully represents *Archibald F. Scott*
of *Boston* in said District *Organ Builder* an Alien, and a free white
person; that he was born in *Halifax Nova Scotia*

the *ninete* day of *February* in the year of our Lord eighteen
hundred and *thirty one* and is now about *thirty six* years of
age; that he arrived at *Boston* in the District of
Massachusetts in the United States of America, on or about the
fifteenth day of *October* in the year of our Lord eighteen
hundred and *forty seven* being then a minor under the age of eighteen years;
that it then was, and still is, his bona fide intention to reside in, and become a citizen of,
the United States of America, and to renounce all allegiance and fidelity to every foreign
Prince, State, Potentate and Sovereignty whatsoever — more especially to **Victoria,**
Queen of the United Kingdom of Great Britain and Ireland,

...and he became a U.S. citizen in 1868.

United States of America.

District of Massachusetts, to wit:

At a Circuit Court of the United States, begun and holden at said Boston, on the
fifteenth day of *May* in the year of our Lord
1868, to wit, on the *31st* day of *July*
A. D. 1868, the said *A. F. Scott* was admitted
to become a citizen of the United States of America; and the Court ordered that record
thereof be made accordingly.

Attest,

John G. Hilton, Clerk.

To summarize...

- Archibald came to Boston from Halifax in **1847** when he was **15 years old**.
- Thirteen years later in **1860 he married Mary Crowe** and over the next few years they had 2 girls (Georgina, the oldest girl was from a previous marriage). **In 1860 he also started working at the organ factory.**
- In **1868 he became a citizen.**
- Three years later (1871) he starts work on our house.
- The next year Mary dies.
- Two years later, in **1874, he marries Elizabeth**, runs out of money and gives up our house.

In spite of all these **facts, facts, facts**, I still didn't really know anything about Archibald himself. So... I decided to track down his **great grandchildren** and **ask them** if they knew anything about him.

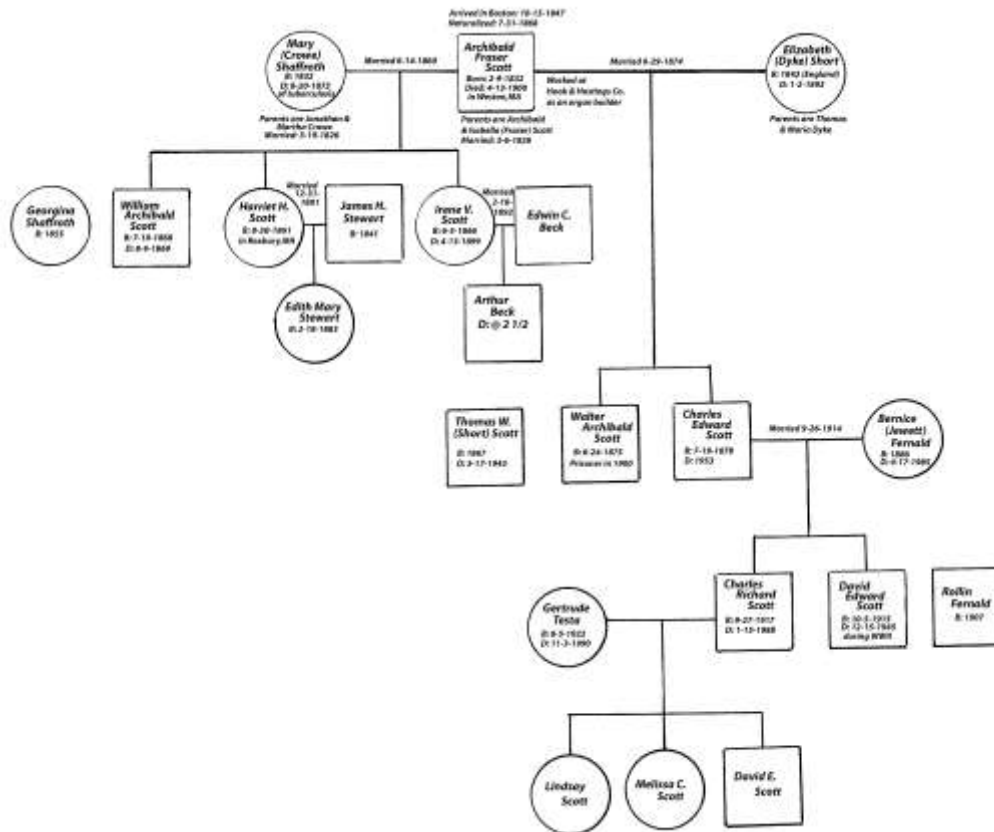

I decided to concentrate on the children of Archibald and Elizabeth because the **relatives of his first marriage to Mary** quickly lost the Scott surname.

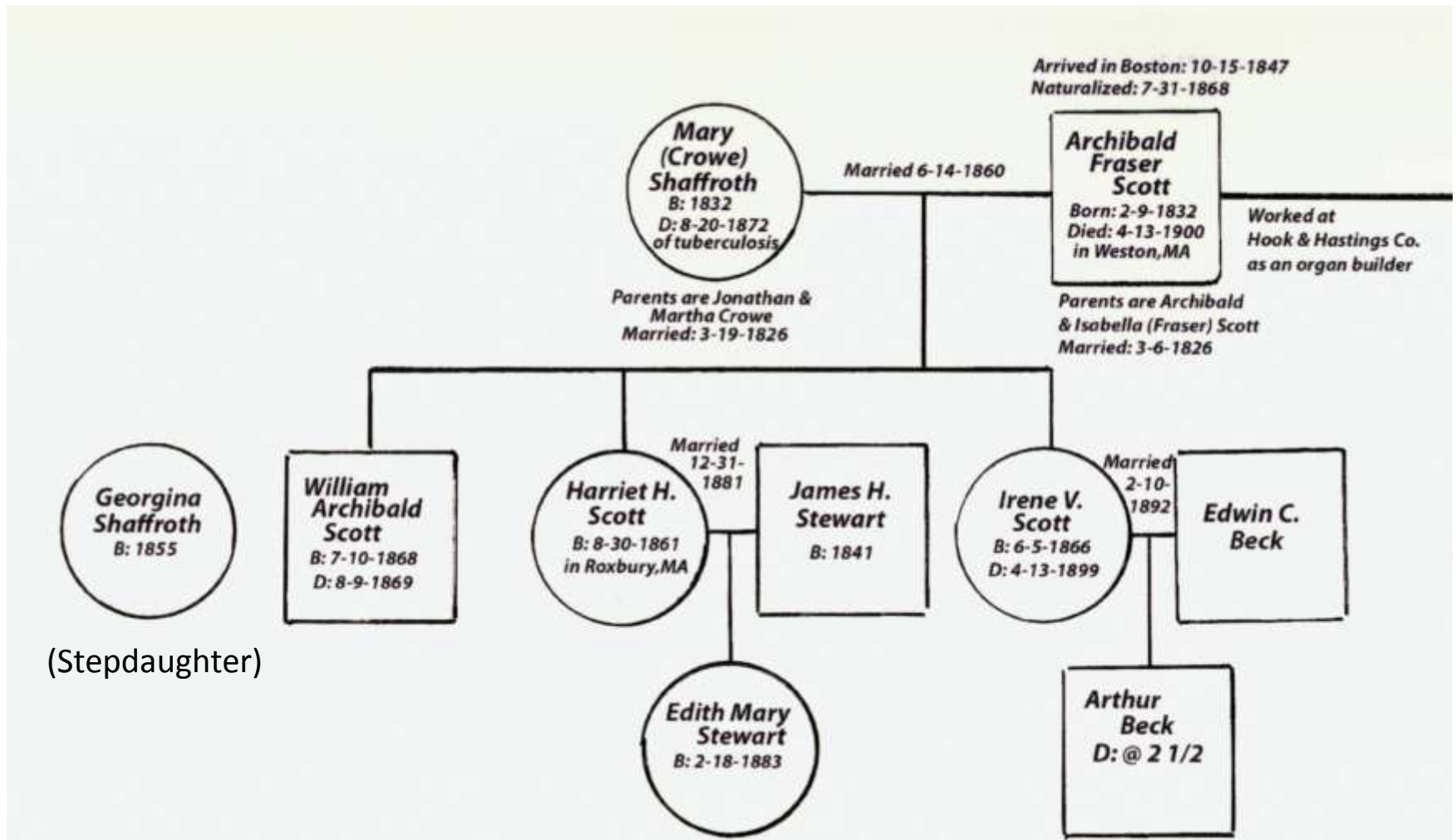

So...**Archibald and Elizabeth** had 2 boys. One ended up in prison (for 20 years!), while the other married Bernice.

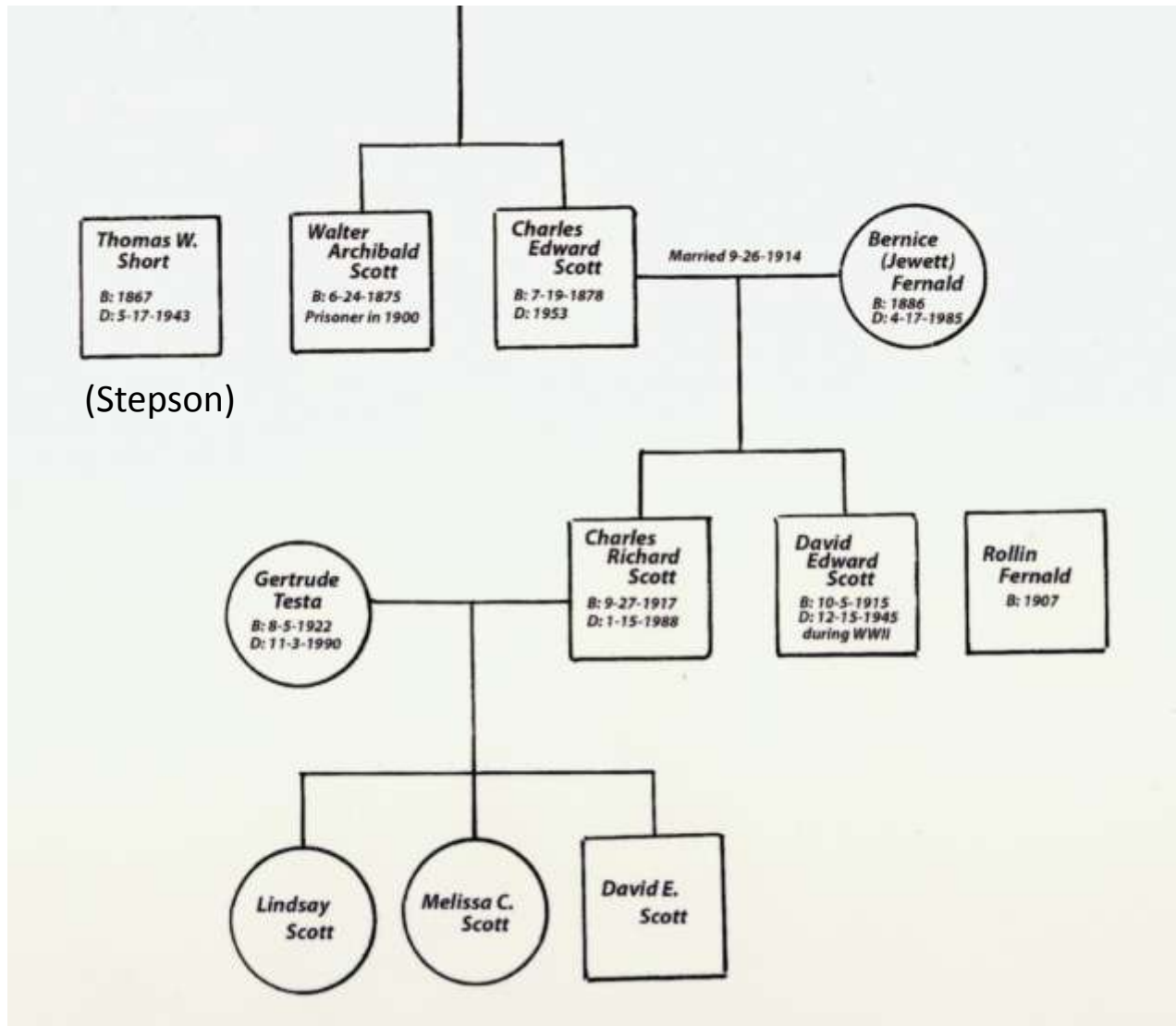

They had 2 boys. One was lost at sea during World War II.
The other married Gertrude.

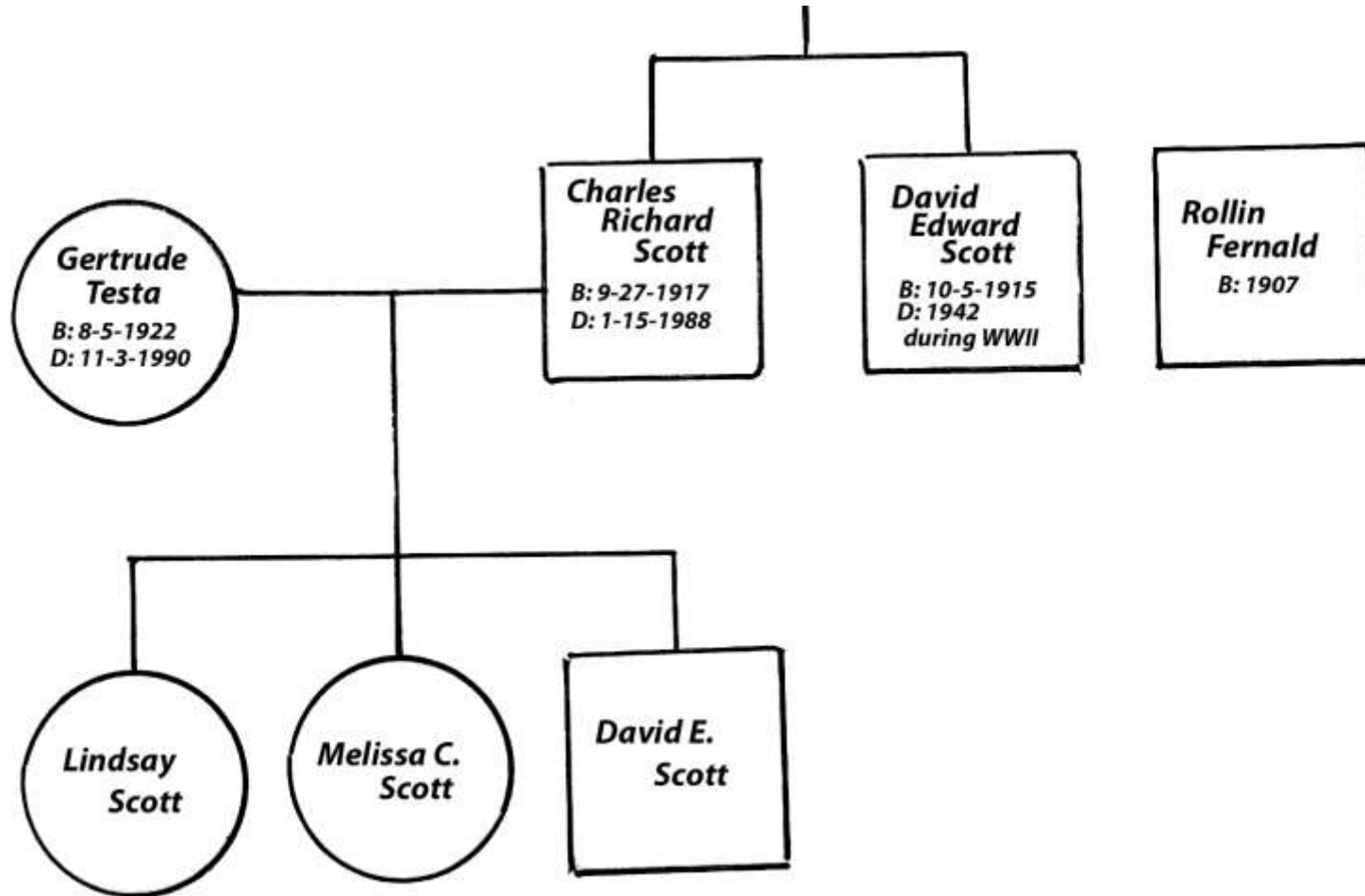

When I found Gertrude's obituary I found Archibald's Great Granddaughter!

Gertrude Scott, 68, of Sudbury

SUDBURY — Gertrude (Testa) Scott, 68, a resident of St. Patrick's Manor, died Saturday, Nov. 3, 1990, at Framingham Union Hospital, following a long illness.

She was born Nutley, N.J., on Aug. 5, 1922, the daughter of the late Michael and Angelina (Dispenzise) Testa.

She was a longtime resident of Sudbury, moving to Southbridge five years ago, following her husband's retirement.

She was the wife of the late Charles R. Scott.

She leaves one son, David E. Scott of Winchendon; two daughters, **Lindsay A. Scott of Aurora,**

Oregon, and Melissa C. Mangini of Natick; four sisters, Catherine Laratta and Helen Celfo, both of New Jersey, Josephine DelTufu of Arizona, and Norma Diorio of Alabama; and a brother, Michael Testa of New Jersey.

Visiting hours will be held Tuesday from 7 to 9 p.m. at the William R. Duckett Funeral Home, 656 Boston Post Road (Rte. 20), Sudbury.

A service of remembrance will be conducted at the close of visiting hours.

Donations may be made in her memory to the charity of one's choice. -

I contacted Lindsay Scott, but **she didn't know anything about him!!!, ...but...**

It's funny, I can't help but relate this to my own life. I've told you that I built my own house and load of other structures, furniture, metalwork, mechanics... I've been working with my hands since I was very young. Something that strikes me - in junior high school I happened to be the first and only girl in 1968 allowed to take a mechanical drawing class. I have always since enjoyed an aspect of mechanical drawing called geometric construction, using drawing tools to solve geometric problems and draw geometric shapes. I taught that unit right up until retirement as an Industrial Arts Technology teacher. During high school and a few years after, I worked for a civil engineering firm plotting and drawing various land plans. I remember in high school art class, designing and making a tent like structure of folded paper that was either hexagonal or octagonal in shape. I then made a full size structure in cardboard and it was photographed and appeared in Sudbury's newspaper. I have that somewhere. The first home I owned, I built a modified octagon deck around my octagon hot tub. Later I added a larger octagon patio type deck. It's kind of weird to see the shape of this amazing house and know I have always been fascinated with shape, structure, design... It's a rather emotion provoking feeling.

(She also remembered her Uncle Walter's notched gun)

Before pursuing other great-grandchildren I took a few “detours”. First, ...to the Organ Factory where Archibald worked. **The Hook & Hastings Organ Factory** was originally located in **Boston at Roxbury Crossing**.

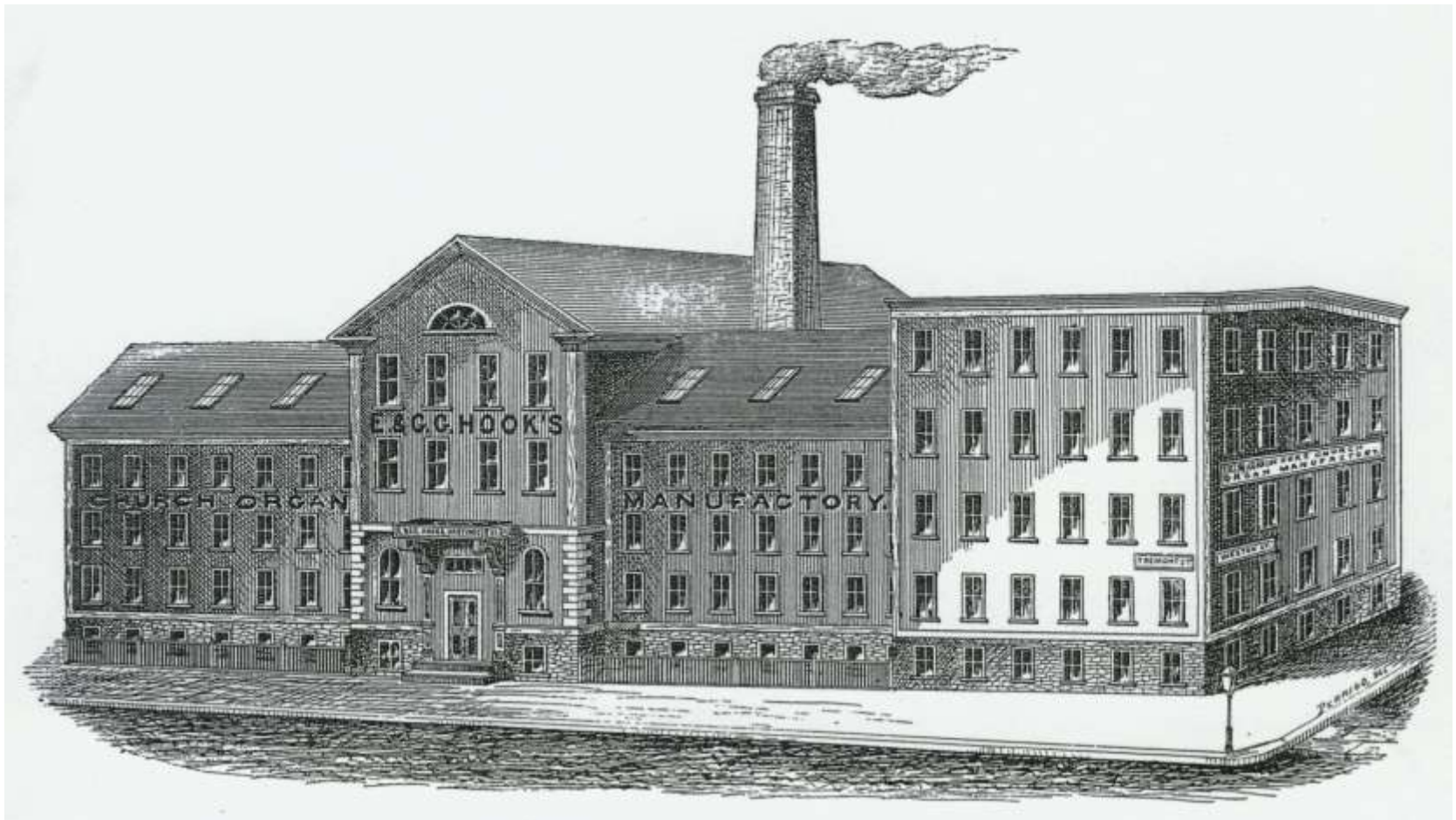

In the late 1880's Hastings decided to relocate the factory to the farm fields across from his boyhood home in **Weston, MA.** (which explains why Archibald was buried in Weston!) Hastings built a huge factory next to the railroad line...



...and built “**cottages**” for his employees (they paid less renting a cottage than a 3-room flat in Boston). Archibald lived in one of these on White Street.



The Organ Factory community was very “enlightened”. There was a club that sponsored debates, concerts, plays & dances. The community Center had a library and game room.



I researched all this at the **Weston Library & Weston Historical Society**. They told me that Archibald's gravestone was at the **Linwood Cemetery** in Weston. Lindsay's mother & father, grandmother & grandfather & great-uncle were buried with him.



I even found his obit in a local paper.

A Achibald Frazer Scott died quite suddenly last Friday while sitting in his chair. He was born in Halifax, N. S., and was 67 years, 2 months, 8 days old. His remains were buried Monday.

The other detour I took led me to **Halifax, Nova Scotia** where I bonded with some local genealogists at the **Nova Scotia Archives**.



Mostly, I was searching for John Scott, Archibald's brother (or maybe his cousin?). What I found was Archibald's baptism records which showed that Archibald was actually born February 9, **1832**.

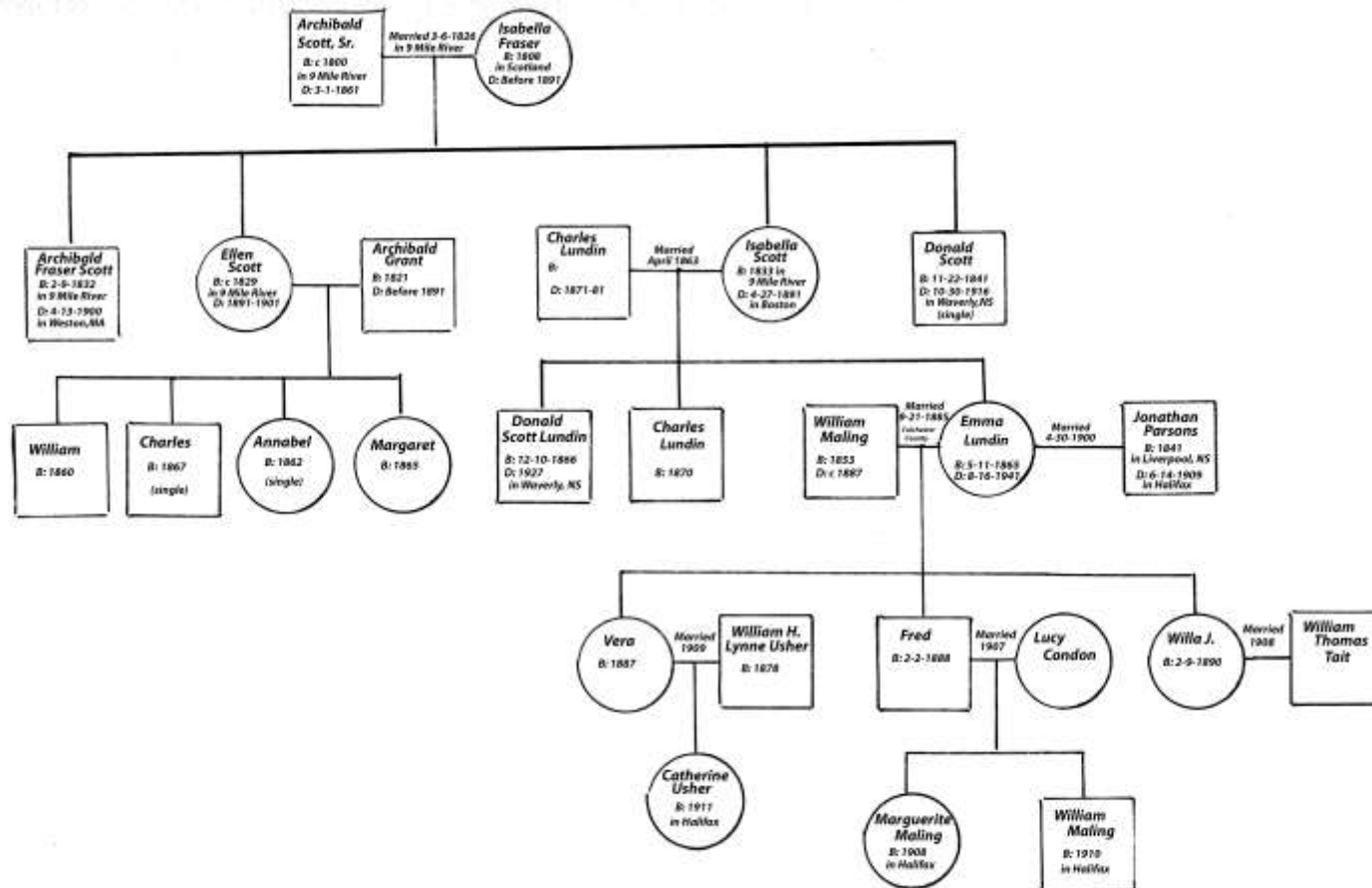

It was at this point that I noticed some things just didn't add up.

As you can see from this genealogical chart, Archibald had one brother named **Donald**. Archibald did have a cousin, John Scott, 19 years old in 1871, but according to the records he was living with his parents in Nova Scotia. Where's John Scott???

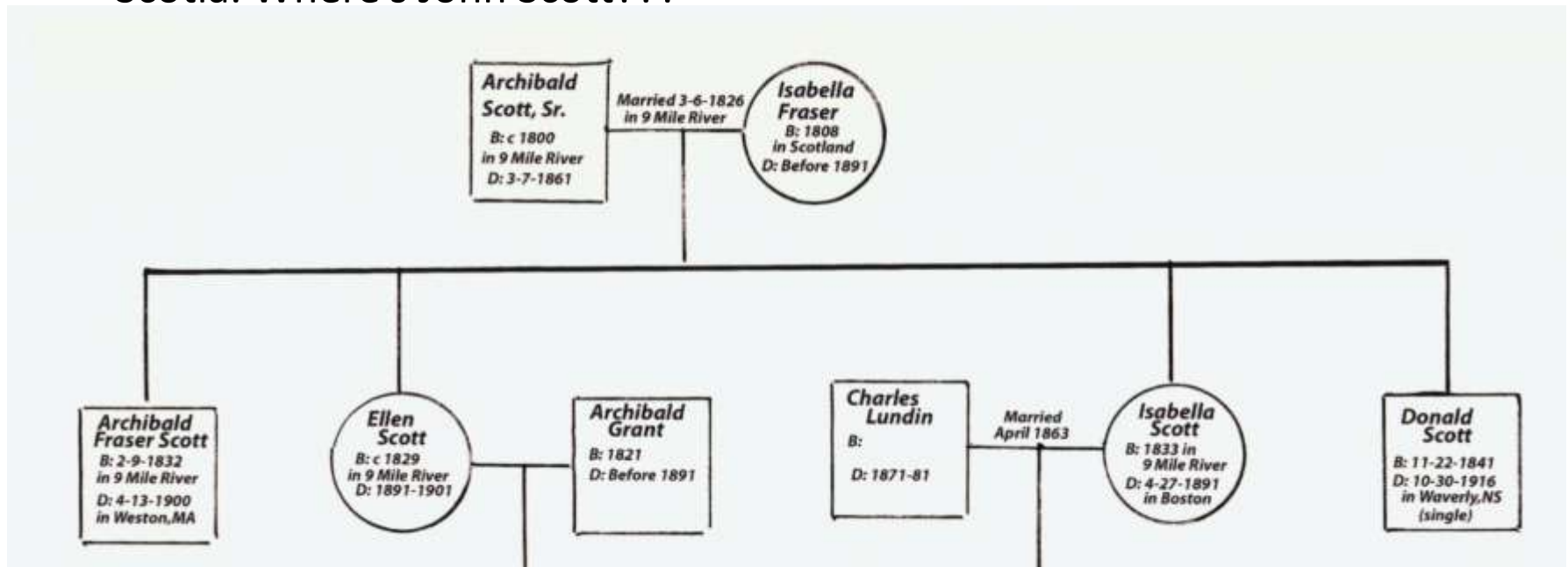

Recently I had reread the original mortgage (dated 1870) and it stated that both Archibald & John were “**unmarried**”. But Archibald, when he signed this, had been married to Mary for 10 years and had 3 girls.

its thereof. In witness whereof we the said Archibald
Scott and John Scott both being unmarried have herunto set
our hands and seals and affixed and cancelled the stamp re-
quired by law this twenty third day of March in the year of our
Lord one thousand eight hundred and seventy one. John Scott

Also, I noticed on the 1874 tax records there was an “a” next to Archibald & John’s names. This meant they were aliens, but we know that Archibald became a naturalized citizen in 1868.

Archibald Scott	a	Carp
John Scott	a	" "

And then one of my neighbors told me about an article (posted on the **JP Historical Society** website) written in the Boston Daily Globe in 1908.

TWELVE-SIDED HOUSE

Dodecagonal Dwelling, Perched on a Cliff in Jamaica Plain, is a Rare Sight—Owned by Mrs Rich of Salem, Who Calls It Her "Castle"—Built by Two Scotchmen for Their Own Bachelor Quarters—Circular and Hexagonal Rooms—Odd Doors and Windows—Walls Full of Closets.



DODECAGONAL HOUSE,
17 Cranston Street, Jamaica-Plain.

It read:

About 40 years ago two brothers from Scotland began the erection of a dwelling, which they intended should be used for their bachelor apartments.

To summarize...

- John Scott is no where to be found
- According to the mortgage Archibald is single, but in fact he's married with 3 kids
- The tax records say he's an alien, but he became a citizen 3 years earlier.
- An article in the Globe claims 2 brothers from Scotland built the house!

My friends at the Nova Scotia Archives suggested that maybe I had the wrong Archibald Scott.

My first instinct was to reject this outright.

I mean...in 1908 the reporter from the newspaper probably interviewed a few neighbors, who probably never actually met Archibald & John (it was 34 years since they'd worked on the house).



Archibald & John both had the last name **Scott**. People could have heard :
“the Scott’s are working on the house” and assume that they were from
Scotland. Or maybe Archibald told the neighbors he was Scottish because his
mother was.



Archibald Fraser Scott was 39 when he started work on the house. His wife was home with the kids. People might have assumed he was a bachelor...

Maybe he said that he was a bachelor in the mortgage because he worried that Bowe would never sell him the land if he knew he was married with 3 kids???

maybe, maybe, maybe...

So I decided to revisit the **City Directories**...

I discovered what I (and the Boston Landmark's Commission) missed:
Namely that **in 1871** an **organ builder** named **Archibald Fraser Scott** was living at **9 Avon St. in Roxbury** AND the same year a **carpenter, Archibald Scott** was living at **1366 Tremont Street**...

Scolley, see Scully
Scotland Robert F. grocer, 1025 Tremont, h. 1023 do.
Scott Alexander, butcher, h. 205 Dorchester ave.
Scott Archibald, carpenter, house 1366 Tremont
Scott Augustus E. counsellor, 7 Court square, room
17, house at Lexington
Scott A. F. organ builder, house 9 Avon pl. wd. 15
Scott Charlotte, widow, rear 49 Beverly
Scott Daniel, laborer, house 342 North
Scott Daniel, laborer, house 14

...AND at that same address lived a **John Scott** who was also a
...**carpenter!** (whoops)

Scott John, teamster, house 14 Conant
Scott John, machinist, house 4 Waltham
Scott John, stonecutter, house 50 Orange [ave.
Scott John, sexton, h. Osgood court, n. Shawmut
Scott John, carpenter, house 1366 Tremont
Scott John, painter, bds. 37 North square
Scott John, peddler, house rear 448 Hanover
Scott John, machinist, house 15 Chadwick

It looked like the **Boston Landmark Commission's Report was wrong.**

Two Archibald Scott's lived in Boston, one an organ builder and the other a carpenter living (for at least one year) with his brother(?) John.

Still...not a complete loss:

- I got a cram course in genealogy.
- It was fun to discover Gertrude's obit and talk with Lindsay.
- I got a trip to Halifax
- And after my return... I got several emails a day from John & Scott (ironic because I was looking for a John Scott!) from the Nova Scotia Archives with suggestions and leads.

And I can understand why the Boston Landmark Commission thought an organ builder might have designed and built house.



In fact, when I was in Halifax I saw the shape of the Citadel, a fort on top of a hill in the middle of downtown, and I thought I saw the shape of our house.



Another perk from my research... a book called **Buildings of Massachusetts** with a picture of our house on the back cover!

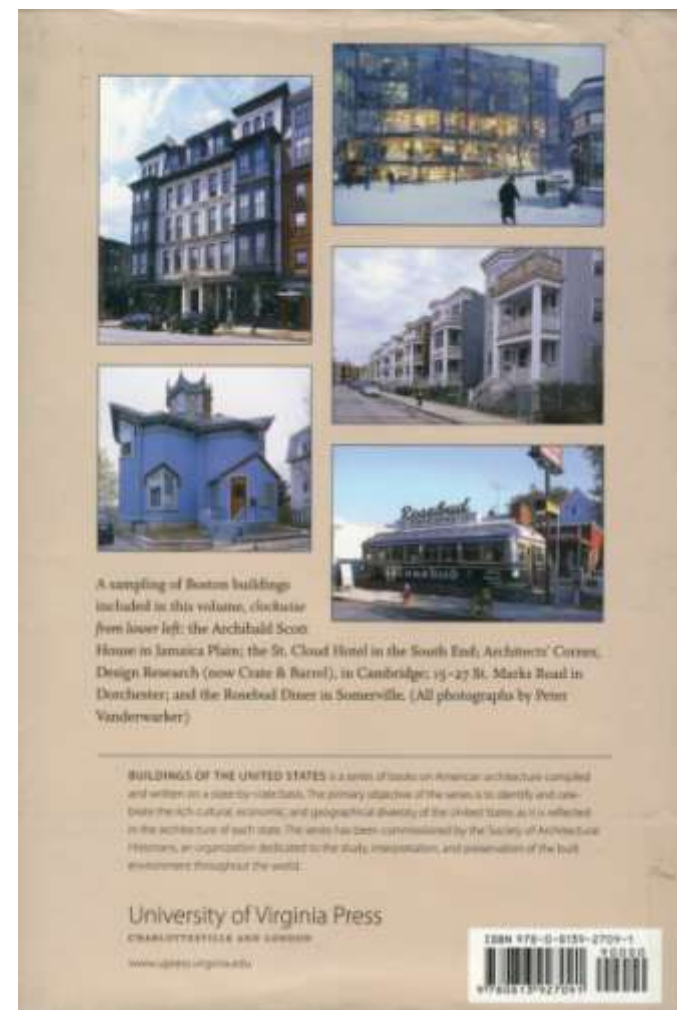
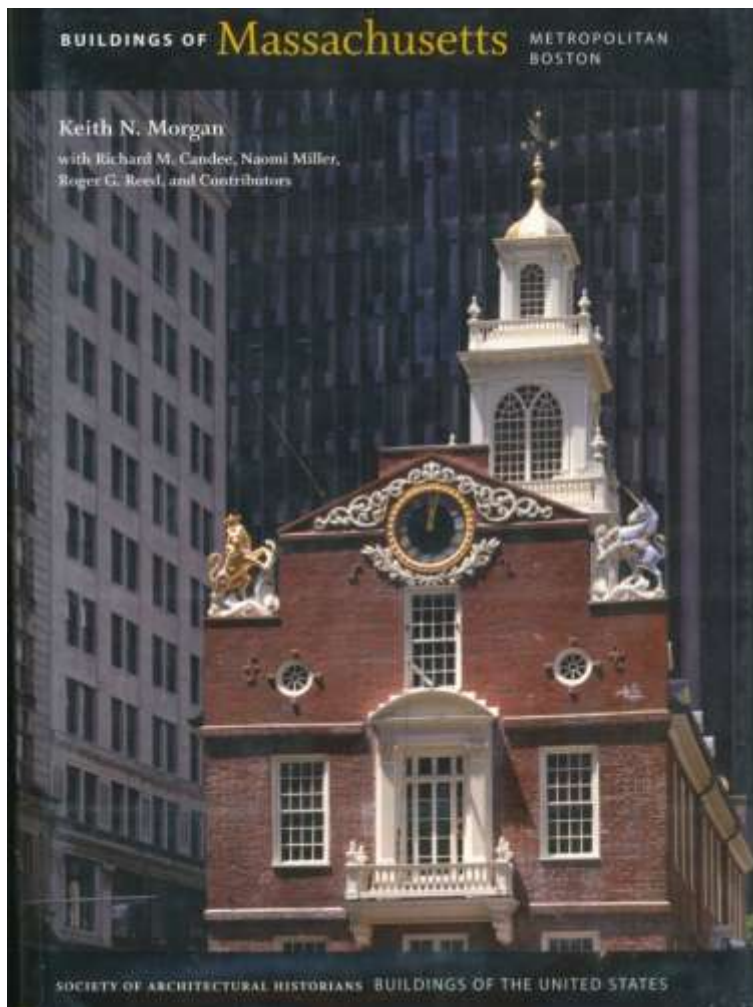

Also there were the families I found who lived in our house before us. I found them using the **Boston List of Residents** (on the BPL Website).

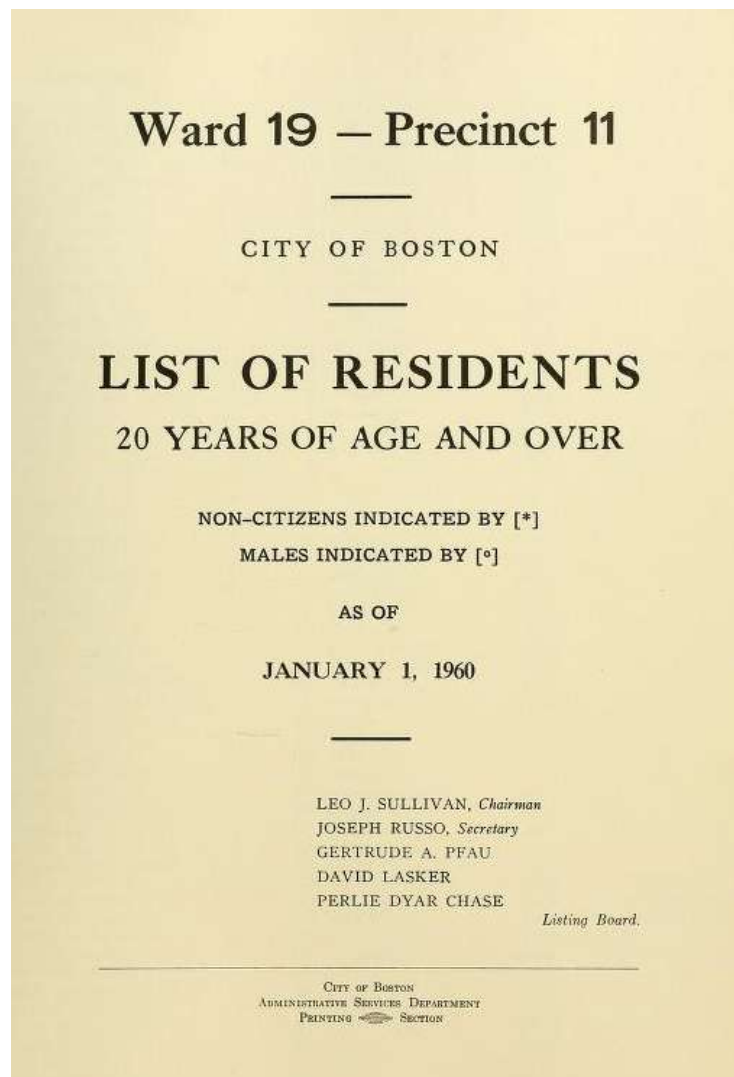

These families provided me with a photo of our house from 1950
(before the house had the enclosed porch...



...and another around 1960 after the enclosed porch was added)...



...and even an action-shot capturing a robbery taking place in our backyard.



I also found a rear view shot of the house showing the triple-decker that burned down in 1975.



The fire was the work of an arsonist and our house was spared only because firemen doused our home with water.

Suspicious fire damages 2 Jamaica Plain houses

Fire caused \$20,000 damage to two vacant three-story houses in Jamaica Plain last night. Fire officials said the fire is believed to have been started by vandals.

Capt. John Collins of the Boston Fire Department said the fire apparently started on the rear stairway of 15 Cranston st. It quickly spread through the building and across an alley to a house at 15A Cranston st.

The houses, both

boarded up, were situated on the top of a hill, and the fire could be seen for many miles. Low water pressure hampered fire-fighting operations.

According to Collins, the houses were badly damaged but not destroyed. He said the first house was a wooden building and the second was brick.

Collins said the three-alarm fire was being investigated by the arson squad.

Courtesy of:
Remember Jamaica Plain

These families told me stories...

- About a general store, a few doors down, that sold eggs and bread and butter, because getting up the hill was so hard in the winter
- About a prankster ghost in a Fedora who opened doors that were left closed and unmade beds
- About how living on our street was like living in a small village with scores of children and a few old women sitting on chairs in the street ever vigilant.

Epilogue

So...I've spent the last few months trying to track down the carpenters, Archibald & John Scott, but I've had **absolutely no luck**.

- They're not in the **U.S. or Canadian Census**
- They're not in the **Immigration records** or **Passenger records**
- In fact...except for the City Directories & Tax Records from 1871-1874 **...they don't exist**

And that's where the story would end, **except...** I recently came across a old advertisement for the organ factory while it was still in Boston...

...and I noticed it was located on **1131 Tremont Street**. Archibald Scott (the carpenter) and John Scott lived at **1366 Tremont Street** in 1871, **just down the block!**

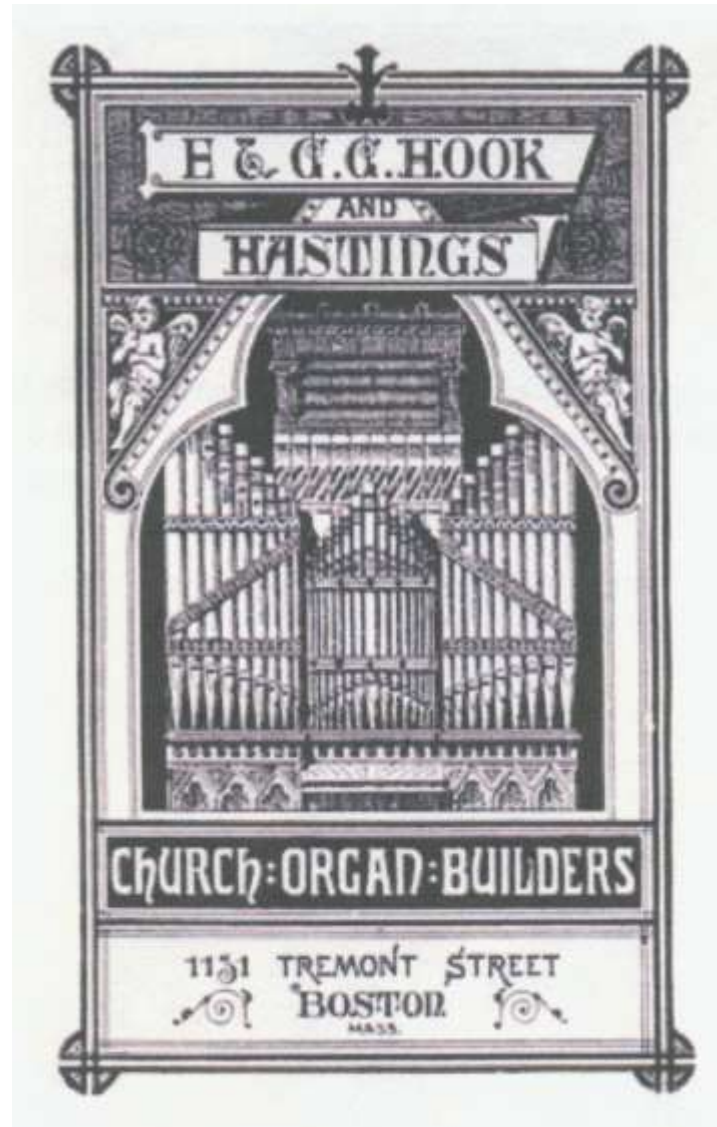

And the next year, 1872, Archibald Scott (the carpenter moved to 3 Drew Place, **literally around the corner from the factory!!!** Why???)

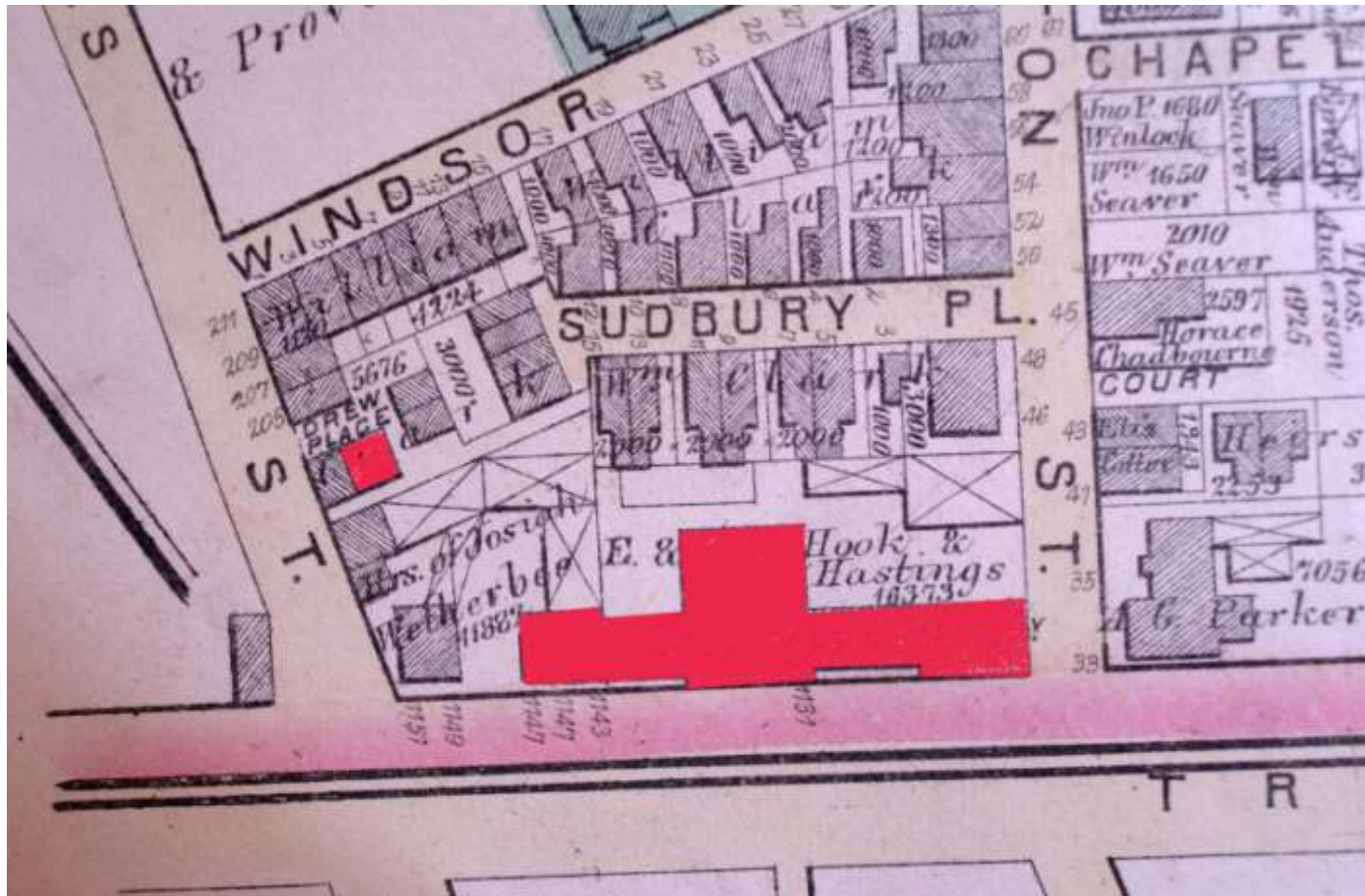

In fact both Archibald Fraser Scott (organ builder) and Archibald Scott (carpenter) live within a few blocks of the organ factory and each other.

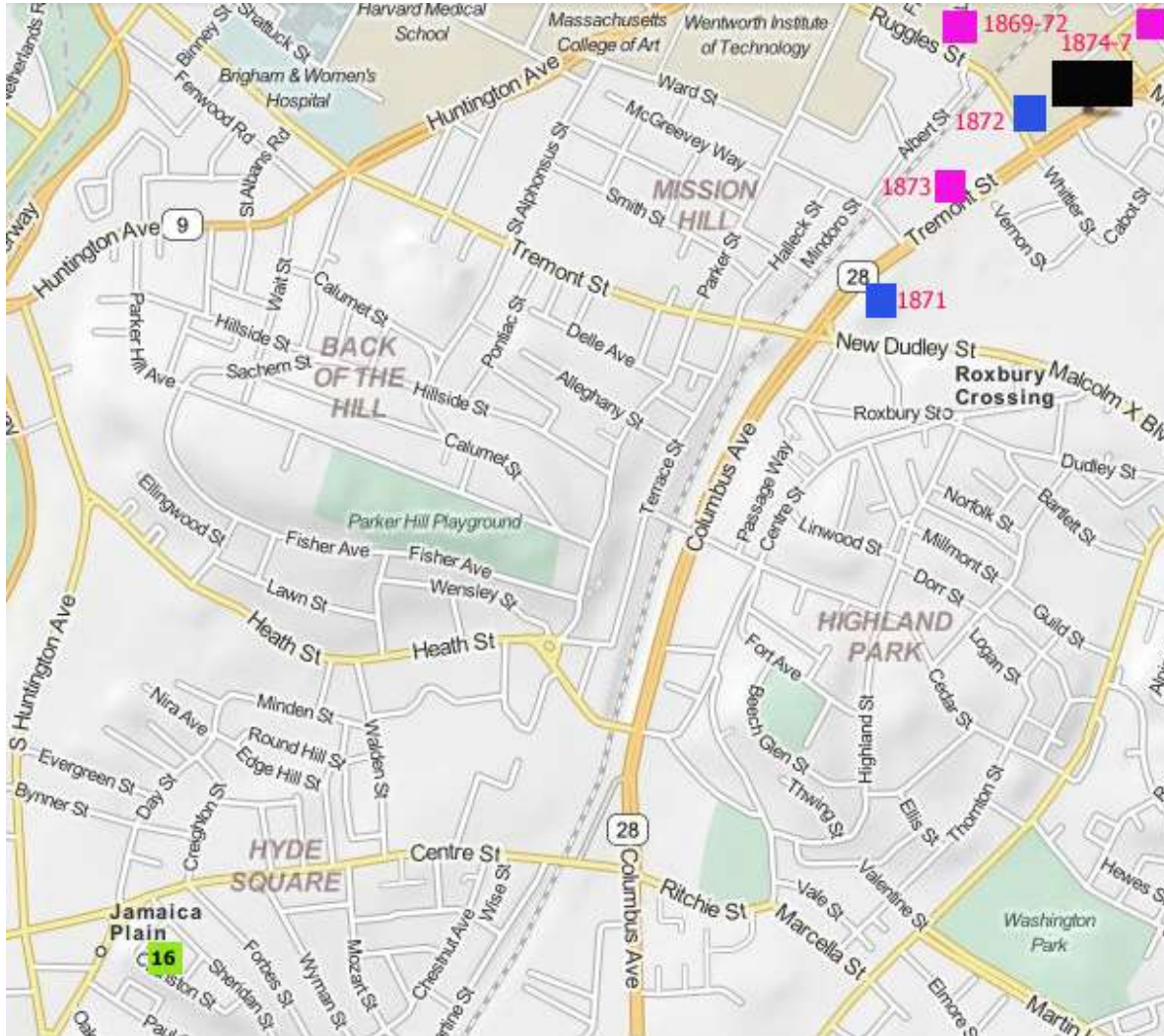

Carpenter
Organ Maker
16 Terrace Avenue
Hook & Hastings

The carpenter could have lived anywhere (in a city of over 250,000 people), but he lives next to the organ factory. That strikes me as really odd.



This black dot is our house.

Inside this black dot is the organ factory, the carpenter & the organ builder.

Special thanks to the Norman Leventhal Map Center for this 1870 Map of Boston

Also, in all the years the organ builder is listed the carpenter only shows up twice in the City Directories.

<u>Archibald Fraser Scott (organ builder)</u>		<u>Archibald Scott (carpenter)</u>
1860	Tremont Street	(Rox. Dir.)
1862	103 Tremont Street	(Rox. Dir.)
1864	110 Tremont Street	(Rox. Dir.)
1866	Cabot (corner of Culvert)	(Rox. Dir.)
1868	181 Cabot Street	(Boston Dir.)
1869	9 Avon Place	(Boston Dir.)
1870	9 Avon Place	(Boston Dir.)
1871	9 Avon Place	(Boston Dir.)
1872	9 Avon Place	(Boston Dir.)
1873	10 Riverside (noted as carpenter!)	(Boston Dir.)
1874	45 Weston	(from Tax Records)
1875	45 Weston	(from Tax Records)
1876	45 Weston	(Boston Dir.)
1877	45 Weston	(Boston Dir.)
1878	93 Roxbury	(Boston Dir.)
1879	93 Roxbury	(Boston Dir.)
1880	94 Vernon	(Boston Dir.)
1881	_____	
1882	165 Roxbury	(Boston Dir.)
1883	165 Roxbury	(Boston Dir.)
1884	165 Roxbury	(Boston Dir.)
1885	165 Roxbury	(Boston Dir.)
1886	99 Vernon	(Boston Dir.)
1887	99 Vernon	(Boston Dir.)
1888	99 Vernon	(Boston Dir.)

1386 Tremont Street (with John Scott)

3 Drew Place

- Is it a coincidence that the carpenter lived next to the organ factory and within a few blocks of Archibald Fraser Scott???
- Is it possible they're the same person?

One scenario is that for two years Archibald Fraser Scott rented one address for his family and the other as a workshop, near the Organ Factory so he could use some of the equipment in off hours to make the hexagonal shingles, strange shaped windows, etc.

He registers his home under his formal name (A.F.Scott) and his “business” under his more informal name Archibald Scott.

He starts a partnership with a Scotsman named John Scott (no relation) who helps him build his dream house.

John remembers Fingal’s Cave, off the coast of Scotland, close to where he grew up...

...with it's hexagonal columns of basalt.



(similar to the “Giant’s Causeway” in Ireland)



And he says to the organ maker/carpenter: “Why not build a house shaped like 3 hexagons “pressed together” ...?”



Of course this is just speculation.

The question is...should I be finding other members of Archibald Fraser Scott's family...or should I be on the next flight to Scotland???

I could use some help.

